

UNLESS OTHERWISE STATED:  
 ALL RESISTANCE IN OHMS  
 ALL RESISTORS 1/4W, 5%  
 ALL CAPACITANCE IN FARADS

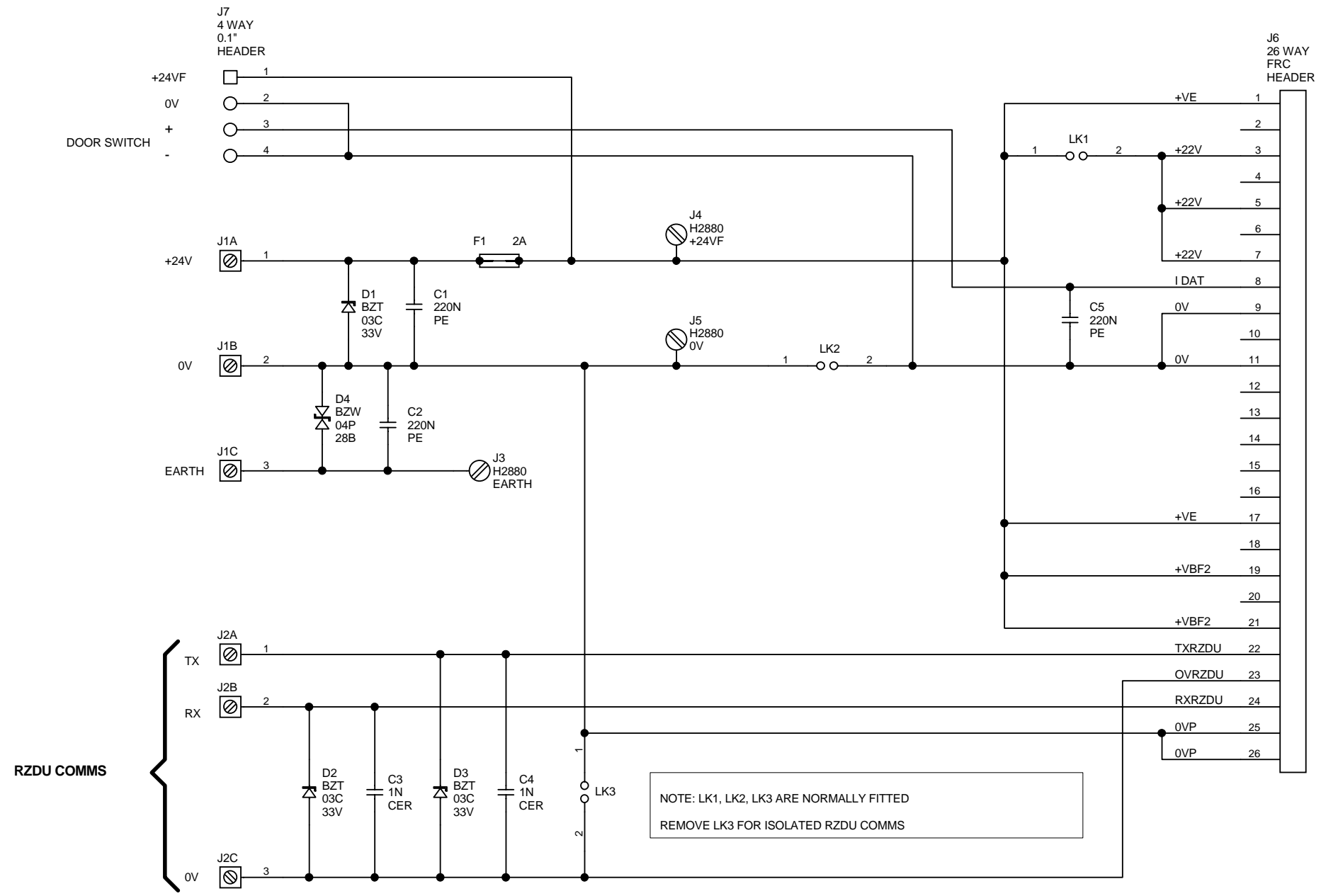

NOTE: LK1, LK2, LK3 ARE NORMALLY FITTED  
 REMOVE LK3 FOR ISOLATED RZDU COMMS

4-Nov-1998  
 11:30:50

CONFIDENTIAL: THIS DOCUMENT MUST NOT BE COPIED NOR THE CONTENTS PASSED ON TO ANY THIRD PARTY WITHOUT THE CONSENT OF THE COMPANY.

ISS/REV	AMENDMENTS	ECO	DRN	CHKD	AUTH	APVD	DATE
2	ADDED CONNECTOR J7 & CAPACITOR C5; C3 & C4 WERE 10N	2061	TWH	DJG	RAC	DSCP	30.5.94

**F3200  
 CONTROLLER REMOTE I/F BOARD  
 CIRCUIT DIAGRAM**



211 MACES ROAD, CHRISTCHURCH 8006, NZ  
 P.O. BOX 19-545, CHRISTCHURCH 8030, NZ

SIZE	DRAWING NUMBER	SHEET NUMBER	ISS/REV	PART NUMBER
A3	1931-27	1 of 1	2	PA0703