

NOTE:  
WHEN PA1030 PANEL BROKEN INTO ITS TWO SUB BOARDS  
THIS SECTION BECOMES PA0707 (1931-39)

UNLESS OTHERWISE STATED:  
ALL RESISTANCE IN OHMS  
ALL RESISTORS 1/4W, 5%  
ALL CAPACITANCE IN FARADS

NOTE:  
WHEN PA1030 PANEL BROKEN INTO ITS TWO SUB BOARDS  
THIS SECTION BECOMES PA0810 (1931-72)

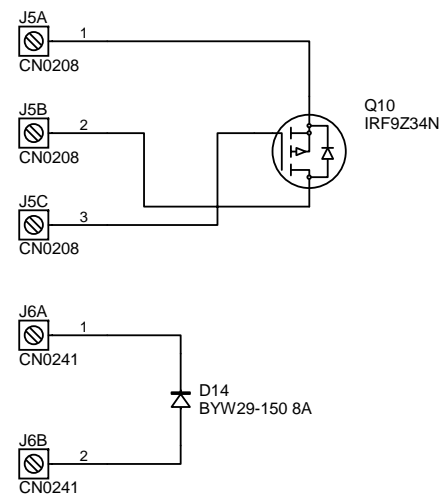

2-Apr-2007  
09:47:39

**CONFIDENTIAL:** THIS DOCUMENT MUST NOT BE COPIED NOR THE CONTENTS PASSED ON TO ANY THIRD PARTY WITHOUT THE CONSENT OF THE COMPANY.

ISS/REV	AMENDMENTS	ECO	DRN	CHKD	AUTH	APVD	DATE
1	ORIGINAL	3552	PAA	RMH	LSC	DSCP	06.07.04
2	Q10 WAS TYPE MTP2955E	3834	GEL	PAA	LSC	DSCP	21.03.07

**tyco** / Safety Products

17 MARY MULLER DRIVE.  
P.O. BOX 19-545,  
CHRISTCHURCH TEL: +64 3 389-5096  
NEW ZEALAND FAX: +64 3 389-5938

**F3200**  
**3A RECTIFIER BOARD**  
**6A FET & RECTIFIER BOARD**

DRAWING No: **1931-133** SHEET **1** of **1**

**A3** | ISS/REV **2** | PART No: **PA1030**