

STYLE 4 (CLASS B) WIRING FOR 2190-9161, OR 2190-9162
 CLASS B SIGNAL ZAM/ WITH REMOTE TELEPHONE STATIONS.

SIZE	DWG NO.	
A	841-804	
J	SK458	
K	SK515	
M	SK714	
R	SL514	

WIRE LEGEND:
 C= CLEAR
 B= BLACK
 R= RED
 S= SHIELD (REQUIRED ON TELEPHONE AND PHONE STATION LINES)

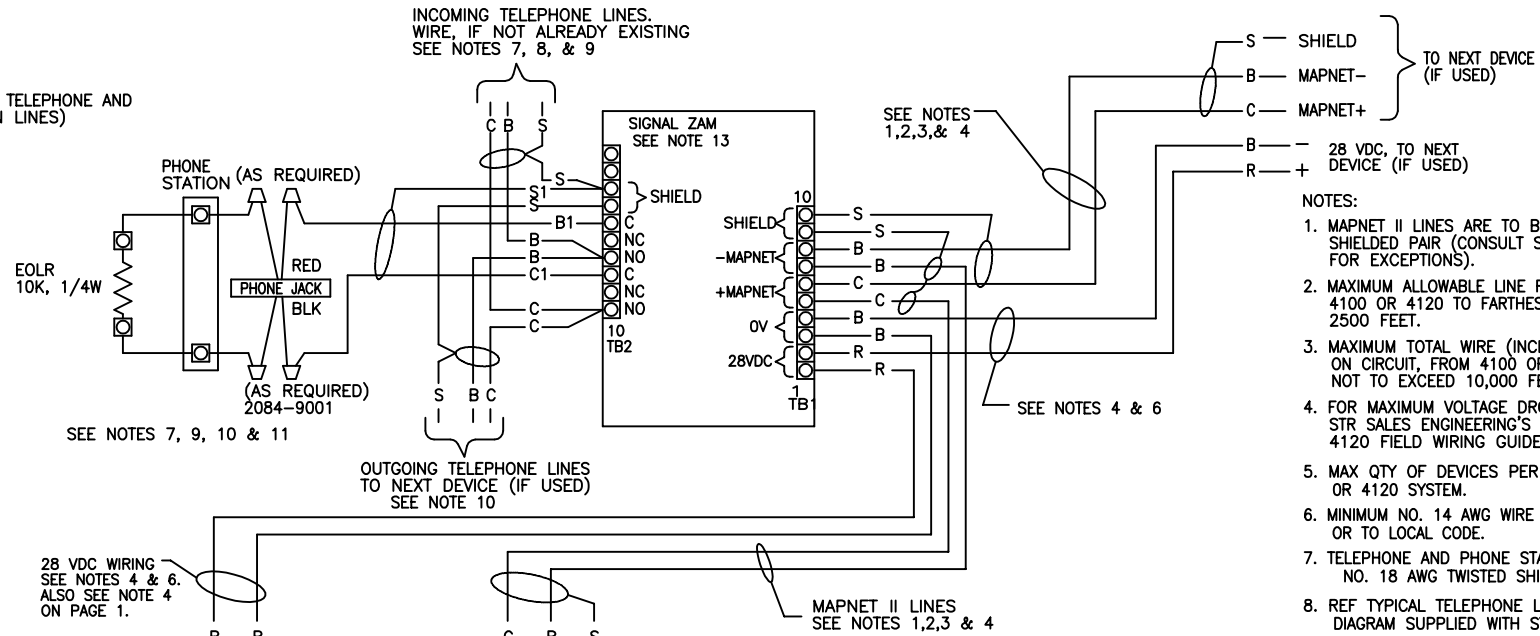

- NOTES:
1. MAPNET II LINES ARE TO BE #18 AWG TWISTED SHIELDED PAIR (CONSULT STR SALES ENGINEERING FOR EXCEPTIONS).
 2. MAXIMUM ALLOWABLE LINE RUN, FROM 4100 OR 4120 TO FARTHEST DEVICE, NOT TO EXCEED 2500 FEET.
 3. MAXIMUM TOTAL WIRE (INCLUDING ALL T-TAPS) ON CIRCUIT, FROM 4100 OR 4120 NOT TO EXCEED 10,000 FEET.
 4. FOR MAXIMUM VOLTAGE DROP, ETC., REFER TO STR SALES ENGINEERING'S 4100 OR 4120 FIELD WIRING GUIDE.
 5. MAX QTY OF DEVICES PER CIRCUIT: 127 IF 4100 OR 4120 SYSTEM.
 6. MINIMUM NO. 14 AWG WIRE FOR 28 VDC WIRING, OR TO LOCAL CODE.
 7. TELEPHONE AND PHONE STATION LINES TO BE MIN. NO. 18 AWG TWISTED SHIELDED PAIR.
 8. REF TYPICAL TELEPHONE LINE INTERCONNECTION DIAGRAM SUPPLIED WITH SYSTEM INSTALLATION PRINTS.

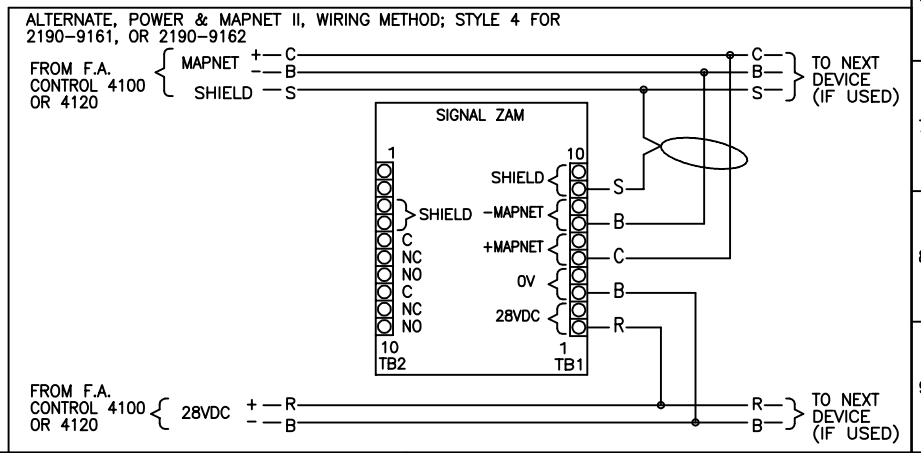

- NOTES:
9. MAX. LINE DISTANCE OF TELEPHONE, PLUS PHONE STATION LINES = 2000 FEET.
 10. TERMINATE THE END OF YOUR TELEPHONE LINES WITH A 22K OHM, 1/2W RESISTOR.
 11. STR MODEL NUMBERS OF REMOTE PHONE STATIONS:
 2084-9002, -9003, -9004(X), -9005(X)
 2084-9006, -9007, -9008(X), -9009(X)
 (X) DENOTES ARMORED CABLE MODELS.
 12. ALL CONNECTIONS MUST TEST FREE OF GROUNDS.
 13. SEE INSTALLATION INSTRUCTIONS 575-279.

REVISIONS				
REV	DESCRIPTION	DATE	BY	CHECKED
A	ISSUED FOR GENERAL INFORMATION	20/07/01	G.Fiala	
REFERENCE DRAWINGS - TITLES				
1				
2				
3				

Simplex
 INTERNATIONAL PTY. LTD.

HEAD OFFICE:
 140 OLD PITWATER RD
 BROOKVALE 2100
 N.S.W.
 AUSTRALIA

ACN : 008 435 443
 PHONE: 02 9466 2333
 FAX : 02 9639 2623

IT IS THE ELECTRICAL CONTRACTORS RESPONSIBILITY TO VERIFY OVERALL DIMENSIONS, CABLE ENTRIES AND SITE ACCESS FOR THE POSITIONING OF ALL EQUIPMENT.

COPYRIGHT © SIMPLEX INTERNATIONAL PTY. LTD. THIS DRAWING AND DESIGNS INCORPORATED ARE THE PROPERTY OF SIMPLEX INTERNATIONAL AND MUST NOT BE REPRODUCED WITHOUT THE WRITTEN PERMISSION OF SIMPLEX INTERNATIONAL P/L

DESIGNED G.Fiala	CLIENT	DRAWING NUMBER 841-804-20
DRAWN MVL	DRAWING TITLE	SHEET SIZE A4
CHECKED	4100 FIELD WIRING DIAGRAM MAPNET II DEVICES	ISSUE A
DATE 20/07/01	PROJECT FIELD WIRING DIAGRAM	DRAWING STATUS INTERNAL
SCALE NTS		FOREIGN NUMBER 84180420

DWG LOCATION : C:\CAD FILES\Projects\MS\F\W PLOT DATE : 07/09/01 11:56
 DWG NAME : 84180420.dwg DWG DATE : 07/09/01 11:53
 RE-PLOT DATE :