

CIM800

Generation 6 MX Detection Range Contact Input Module

Features

- // Compatible with MX Addressable Loop on SIMPLEX 4100ESi, VIGILANT MX1 and VIGILANT MX4428 panels
- // MX Addressable Module
- // Supervise Two Circuits
- // Supervise Multiple Contacts per Circuit
- // Up to 250 Devices per Loop²

Description

The CIM800 Addressable Contact Input Module supervises two circuits of voltage-free contacts such as outputs from extinguishing systems, ventilation controls, fire door controls, sprinkler flow switches, non indicating detectors, etc. The LED illuminates when any input goes into alarm, and can also be programmed to blink when polled by the Tyco MX Control and Indicating Equipment (CIE.). The CIM800 can be configured to supervise:

- Two circuits of multiple normally-open contacts; with short circuit alarm
- Two circuits of multiple normally-closed contacts; open circuit alarm
- Two circuits with a single normally-open contact closing for alarm; with short circuit fault. This requires a resistor in series with the alarm contact and special programming at the MX4428 CIE.

The two inputs may be mapped to different zones on the CIE.

Mounting

The CIM800 is supplied as an open circuit board (PCB) with mounting hardware and End of Line (EOL) resistors. It must be fitted in a suitable enclosure. It may be mounted on a gear plate using plastic standoffs, to an M520 Ancillary Cover and K2 142 back box, or into the D800 Ancillary Housing.

The K2 142 mounting box provides a convenient surface mounting enclosure and the M520 Cover is designed to accommodate the CIM800. The contacts supervised must be voltage free. Do not connect the two circuits of a CIM800 together or join with other MX module inputs. Unused inputs must be terminated with an EOL resistor.

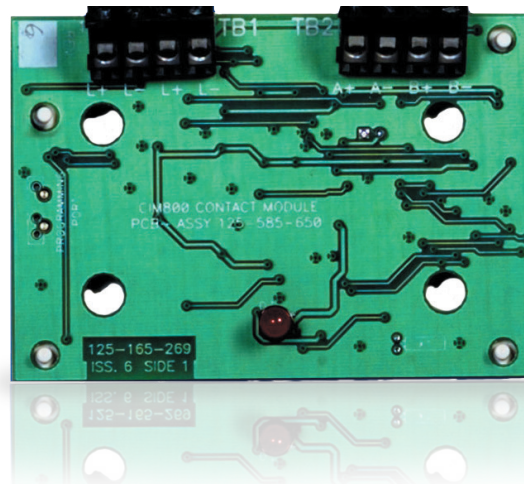

Specifications

Loop Voltage ¹	20V to 40Vdc
Quiescent Current	275µA
Alarm State Current	2.8mA
Circuit Resistance	10 Ohm
EOL Resistor	200 Ohm
Alarm Resistance (s/c fault)	100 Ohm
Max. CIM800 per Loop ²	200/250
Ambient Temperature	-25°C to +70°C
Storage Temperature	-40°C to +80°C
Relative Humidity	10% to 95% (non cond.)

Indoor Applications Only

Dimensions (HWD)	61 x 84 x 25 mm
Wire Size (maximum)	2.5sq. mm

Part Numbers

CIM800	CIM800 PCB ³
M520	Ancillary Cover
K2 142	Back box
557.201.401	D800 Ancillary Housing

1. Addressable loop voltage provided by MX CIE.
2. MX4428/MX1; 4100ESi. Refer to appropriate CIE manual for design specifications.
3. PCB c/w EOL resistor, mounting screws, cover labels.

Address Setting

The CIM800 is supplied with a default (invalid) address of 255 and must be set to the correct loop address using the 850EMT or 801AP MX Service Tool.

Wiring

CIM800 Wiring Options.

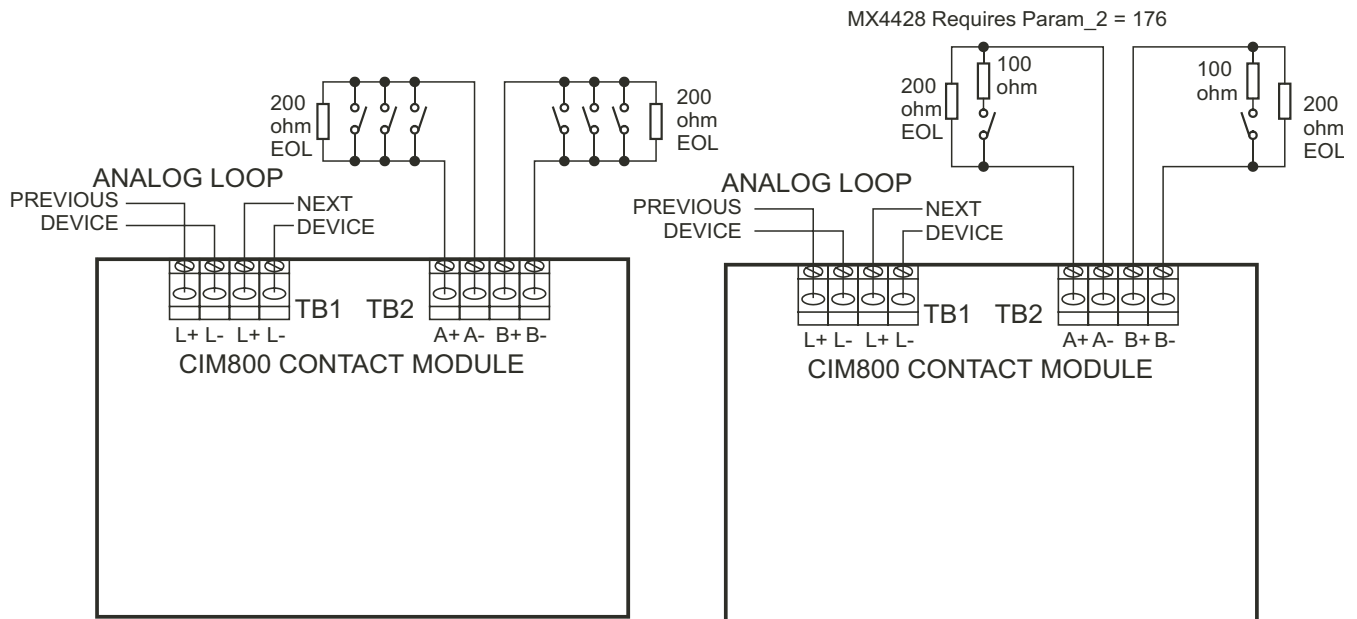

Normally Open

Normally Open, S/C = Fault

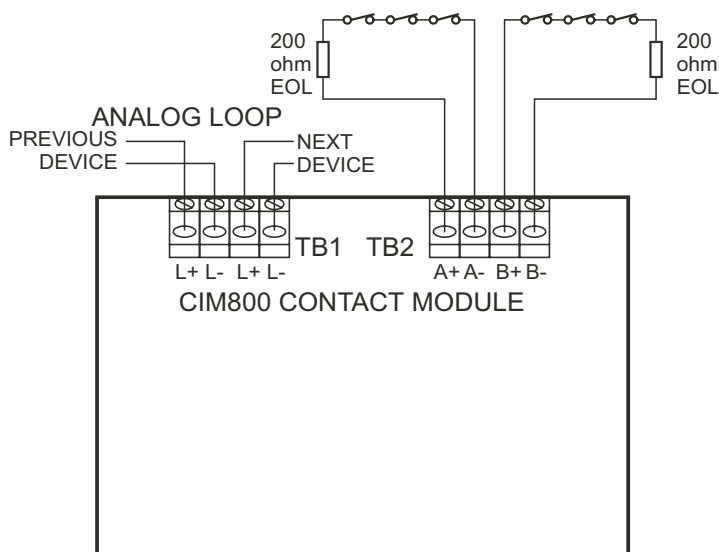

Normally Closed

Unused inputs (A or B) must be terminated with a 200 ohm EOL resistor.

A and B inputs must be voltage free.

Australia

Tyco Fire Protection Products
 Level 3, 95 Coventry Street
 Southbank VIC 3006
 Tel : 1300 725 688
 Tel : +61 3 9313 9700
 Email : tfppcustservice.au@tycofp.com

New Zealand

Tyco Fire Protection Products
 17 Mary Muller Drive
 Hillsborough PO Box 19-545
 Woolston Christchurch 8241
 Tel : +64 9 635 0760
 Email : tsp.sales.nz@tycoint.com