

# INSTALLATION AND MAINTENANCE INSTRUCTIONS

# tyco

## Fire Protection Products

### Model: T131A-Mk2 Plug-in Intelligent Heat Sensor

#### SPECIFICATIONS

Operating Voltage Range:	15 to 32 VDC
Maximum Average Standby Current:	300 $\mu$ A @ 24 VDC (one communication every 5 seconds with LED blink enabled)
Maximum Alarm Current (LED on):	6.5 mA @ 24 VDC
Operating Humidity Range:	10% to 93% Relative Humidity, Non-condensing
Operating Temperature Range:	-20°C to 45°C (-4°F to 113°F)
Height:	51 mm installed in Z131A Base
Diameter:	102 mm installed in Z131A Base
Shipping Weight:	137g
Fixed Temperature Rating:	63°C (146°F)

#### BEFORE INSTALLATION

This sensor must be installed in compliance with the MX4428 Installation Manual (LT0070). The installation must meet the requirements of the Authority Having Jurisdiction (AHJ). Sensors offer maximum performance when installed in compliance with AS1670.1/NZS4512.

#### GENERAL DESCRIPTION

Model T131A-Mk2 intelligent heat sensor uses a state-of-the-art thermistor sensing circuit for fast response. These sensors are designed to provide open area protection and are intended for use with compatible control panels only.

Model T131A-Mk2 is a programmable Type A or Type B heat detector with a fixed alarm temperature of 63°C.

Two LEDs on each sensor light to provide a local, visible sensor indication. Remote LED annunciator capability is also available as an optional accessory (E500Mk2).

Up to 99 sensors and 99 modules may be wired to each MPR addressable loop. Use with Z131A standard base or Z132A Sounder base.

**The T131A-Mk2 requires compatible addressable communications to function properly. Connect this sensor to MPR V3.00 onwards only.**

#### SPACING

All sensors should be spaced and installed in accordance with the requirements of the relevant Authority Having Jurisdiction. For specific information regarding sensor spacing, placement, and special applications, refer to AS1670.1 or NZS4512.

#### WIRING GUIDE

All wiring must be installed in compliance with the MX4428 Installation Manual (LT0070), applicable local codes, and any special requirements of the Authority Having Jurisdiction. Proper wire gauges should be used. The installation wires should be color-coded to limit wiring mistakes and ease system troubleshooting. Improper connections will prevent a system from responding properly in the event of a fire.

Note that addressable circuits with more than 40 devices (1 zone) must be wired in a loop and short circuit isolators used in accordance with the MPR Engineering Manual (LT0140).

#### Remove power from the communication line before installing sensors.

1. Wire the sensor base (supplied separately) per the wiring diagram, see Figure 1.
2. Set the desired address on the sensor address switches, see Figure 2.
3. Install the sensor into the sensor base. Push the sensor into the base while turning it clockwise to secure it in place.
4. After all sensors have been installed, apply power to the control unit and activate the communication line.
5. Test the sensor(s) as described in the TESTING section of this manual.



Dust covers provide limited protection against airborne dust particles during shipping. Dust covers must be removed before the sensors can sense heat. Refit covers to sensors prior to heavy remodeling or construction, and remove on completion.

FIGURE 1. WIRING DIAGRAM:

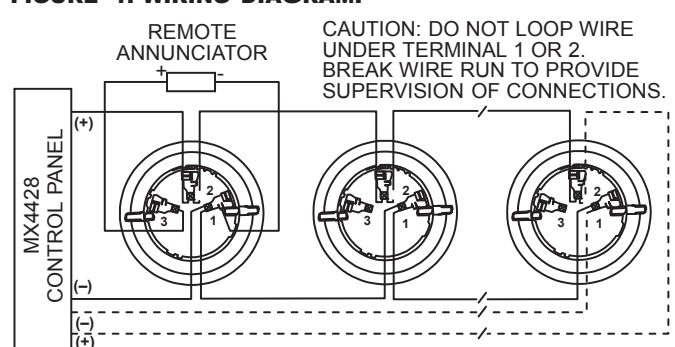

C0129-00

FIGURE 2. ROTARY DECADE ADDRESS SWITCHES:

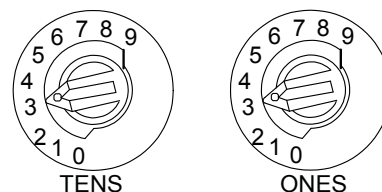

C0146-00

#### TAMPER-RESISTANCE

Model T131A-Mk2 includes a tamper-resistant capability that prevents their removal from the base without the use of a tool. Refer to the base manual for details on making use of this capability.

#### TESTING

Before testing, notify the proper authorities that the system is undergoing maintenance, and will temporarily be out of service. Disable the system to prevent unwanted alarms.

All sensors must be tested after installation and periodically thereafter. They must be tested and maintained in compliance with AS1670.1, AS1851 or NZS4512.

Test the sensors as follows:

#### A. Functional: Magnet Test (not suitable for AS1851 test purposes)

This sensor can be functionally tested with a test magnet. The test magnet electronically simulates heat to the thermistor, testing the sensor electronics and connections to the control panel.

1. Hold the test magnet in the magnet test area as shown in Figure 3.
2. The sensor should alarm the panel.

Two LEDs on the sensor are controlled by the panel to indicate sensor status. Coded signals, transmitted from the panel, can cause the LEDs to blink, latch on, or latch off. Refer to the control panel technical documentation for sensor LED status operation and expected delay to alarm.

**B. Heat Test: X461 Heat Detector Tester**

The Tyco X461 Heat Detector Tester can be used to activate the sensor into alarm. Follow the instructions supplied with the tester, and check the two LEDs on the detector turn on and the control panel goes into alarm.

A sensor that fails any of these tests should be cleaned as described under **CLEANING**, and retested. If the sensor fails after cleaning, it must be replaced.

When testing is complete, restore the system to the normal operation and notify the proper authorities that the system is back in operation.

**CLEANING**

The sensor may be cleaned with a vacuum cleaner to remove dirt and dust from the cover and the thermistor.

If the sensor fails to go into alarm when tested, the sensor should be replaced with a new or refurbished sensor and the dirty sensor sent to a facility for correct cleaning and re-calibration so that it may be reused on this or another installation. Dirty sensors are prone to give nuisance alarms, so it is important to promptly remove and replace them.

Wormald Wollongong NSW has suitable facilities for cleaning and re-calibration work on Tyco and most other brands of detectors and sensors.

**Installation warning** The T131A-Mk2 is not suitable for use when it may be exposed to condensing moisture, mist or water spray.

**Applications Warning** In many fires, hazardous levels of smoke and toxic gas can build up before a heat detection device will initiate an alarm. In cases where life safety is a factor, the use of smoke and/or CO detection is highly recommended. Heat detectors are not considered to provide life safety protection and are generally used where property protection is desired, but smoke or CO detectors cannot be used. Typical heat detector applications are satisfied by the use of rate-of-rise and fixed temperature electronic detectors. The addition of rate-of-rise operation provides faster heat detection for use where temperature fluctuations are controlled and less than 6°C/min. Where temperatures may fluctuate more quickly, use fixed temperature detection only (Type B or Type D).

**FIGURE 3. TEST MAGNET POSITIONING:**

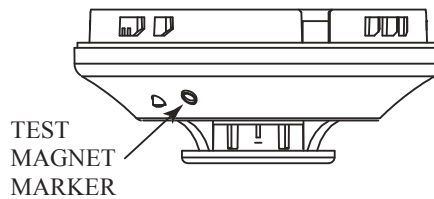
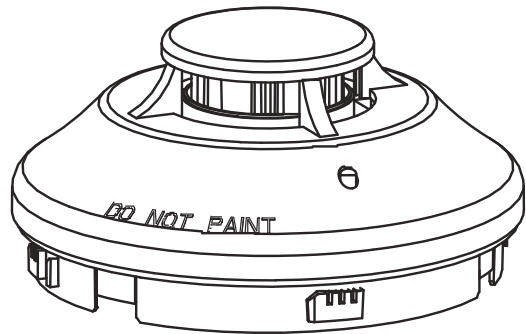
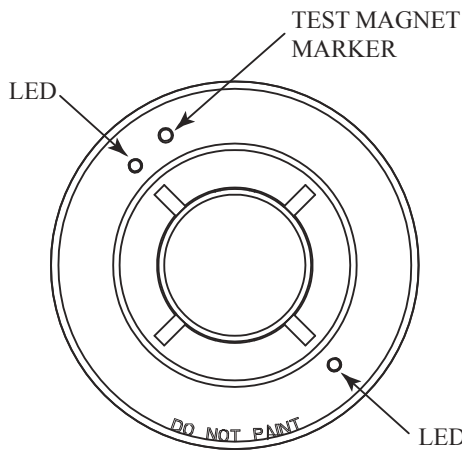

**FIGURE 4:**

**THREE-YEAR LIMITED WARRANTY**

Tyco warrants this enclosed product to be free from defects in materials and workmanship under normal use and service for a period of three years from date of manufacture. The company's obligation of this Warranty shall be limited to the repair or replacement of any part of the product which is found to be defective in materials or workmanship under normal use and service during the three year period commencing with the date of manufacture.

Tyco Fire Protection Products 47 Gilby Rd Mt Waverley, VIC 3149 AUSTRALIA Tel: 03 9538 7220 Fax: 03 9538 7255	Tyco Fire Protection Products 6 Portage Rd P.O. Box 15492, New Lynn Auckland NEW ZEALAND Tel: 09 826 1716 Fax: 09 827 2288
------------------------------------------------------------------------------------------------------------------------------	----------------------------------------------------------------------------------------------------------------------------------------------